

**CUSTOMER RESPONSIBILITIES**

- INSTALLATION OF "Y" AXIS RAILING SYSTEM
- LOCATING & PLACEMENT OF ELECTRICAL PANEL
- ASSEMBLY OF HOSE AND CABLE CARRIER FLEX TRACK SYSTEM
- PROVIDE ELECTRICAL SERVICE & WIRE TERMINATION TO PROVIDED DISCONNECTS
- PROVIDE ALL PLUMBING SERVICES & PLUMBING TO SUPPLY POINT OF MACHINE
- PLUMBING GASES MUST BE LARGE ENOUGH TO SAFELY SUPPORT MAXIMUM MATERIAL PROCESSING
- SUPPLY AND INSTALLATION OF MATERIAL SUPPORT SURFACE
- SUPPLY ADEQUATE & SAFE MATERIAL FIXTURING FOR ENTIRE MATERIAL THICKNESS RANGE & TYPES
- PROVIDE COOLANT FOR DRILLING OPERATION
- SUPPLY ALL TOOLING FOR CUTTING AND DRILLING THAT WILL BE NEEDED FOR STARTUP, TESTING, & TRAINING

NOTE: ALL GAS AND ELECTRICAL INSTALLATIONS MUST BE IN ACCORDANCE WITH STATE & LOCAL CODES

**SYSTEM OPTIONS:**

- AUTO-GAS OXY-FUEL TORCH SYSTEM
- HPR260 AUTO-GAS PLASMA SYSTEM W/ COMMAND THC
- AUTOMATIC CONTROL 10 HP HIGH SPEED DRILL ASSEMBLY
- ARC WRITER MARKING & LIFTER ASSEMBLY
- EMERGENCY PARTS KIT
- OFFICE SEAT OF CADNESTING PRO WITH TRUE SHAPE NESTING
- WATER TABLE MATERIAL CLAMPING KIT
- DRAWING PACKAGE FOR CUSTOMER FAB WATER TABLE & MATERIAL CLAMP SYSTEM

THE SERVICE PANEL AND PLASMA COMPONENTS ARE TO BE WITHIN 15' FROM THE CENTER OF THE LENGTH AXIS OF TRAVEL.

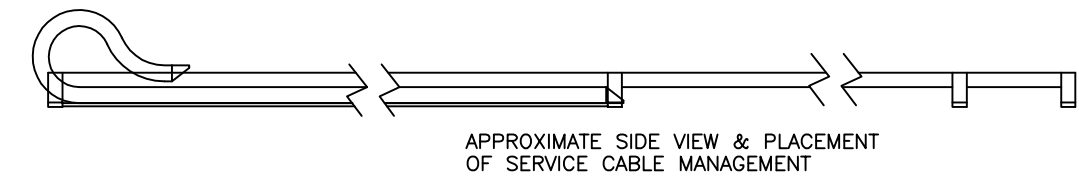
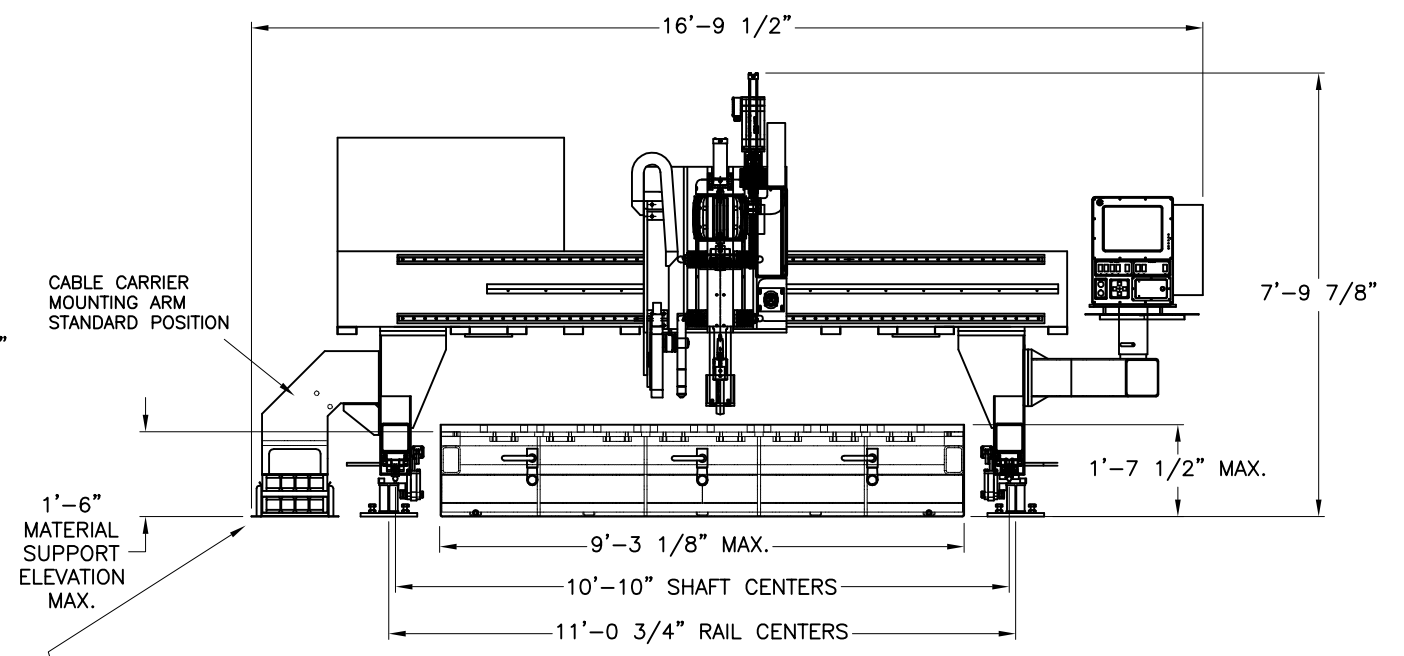
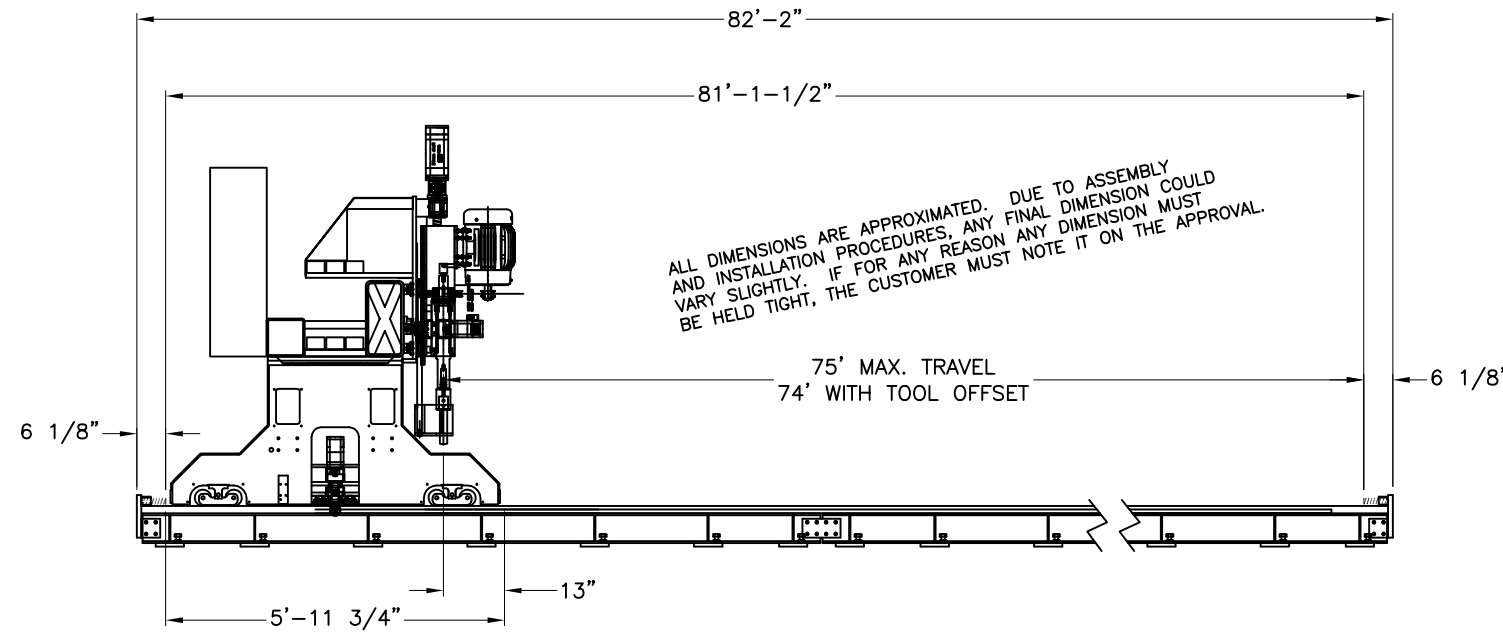
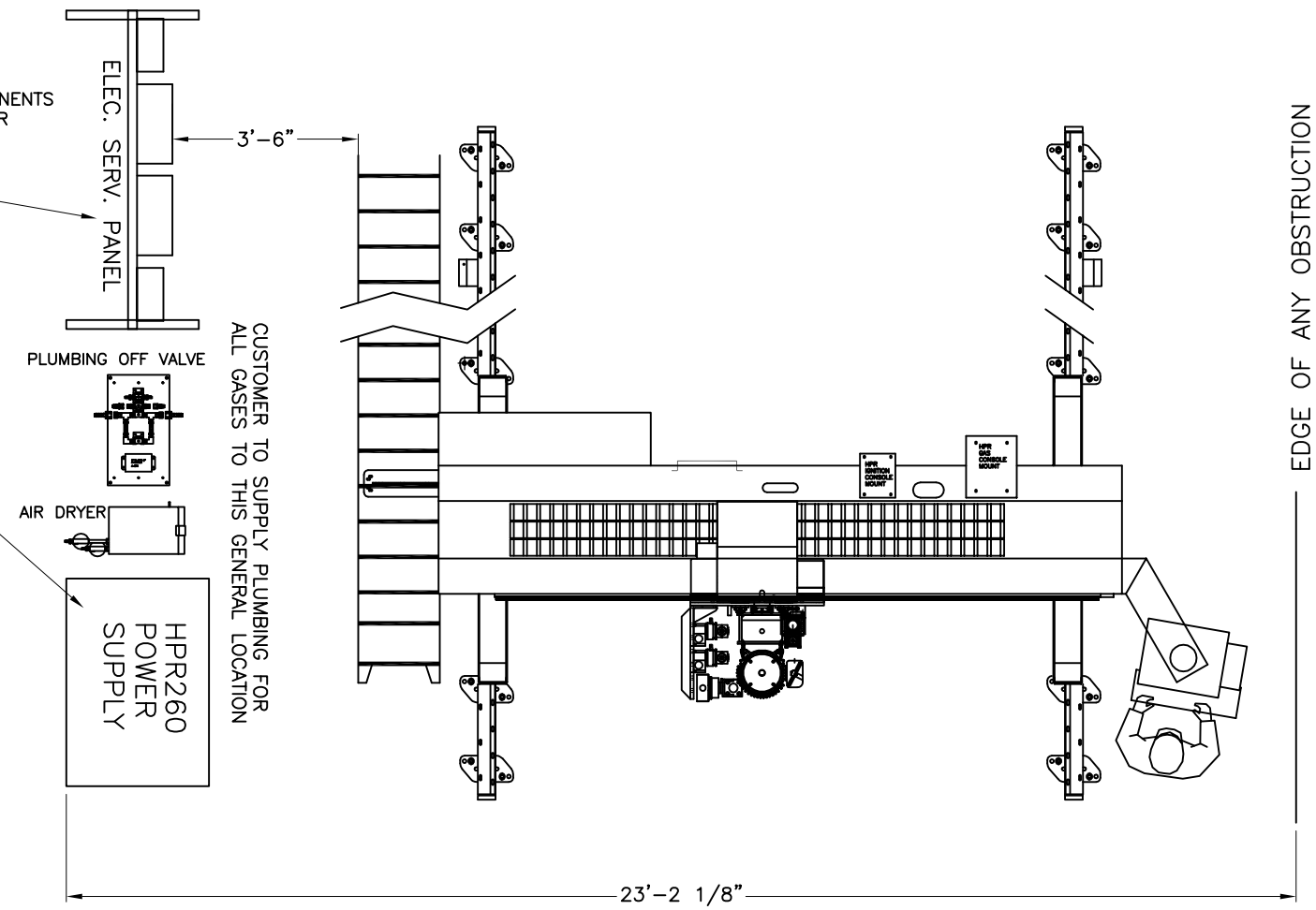

| REV | DESCRIPTION | BY | DATE |
|-----|-------------|----|------|
|     |             |    |      |

© CONTROLLED AUTOMATION, INC.  
BRYANT, ARKANSAS

TITLE: 8'X74' BTD LAYOUT  
General Machine layout

|               |               |                      |
|---------------|---------------|----------------------|
| SCALE: NTS    | DATE: 4/23/08 | JOB NUMBER:          |
| DRAWN BY: JAR | REF. DWG.:    | DRAWING NUMBER: REV: |